

REVISIONES				
Rev.	Symbol	Modification N°	Date	Name

Laser Labeling and Coding

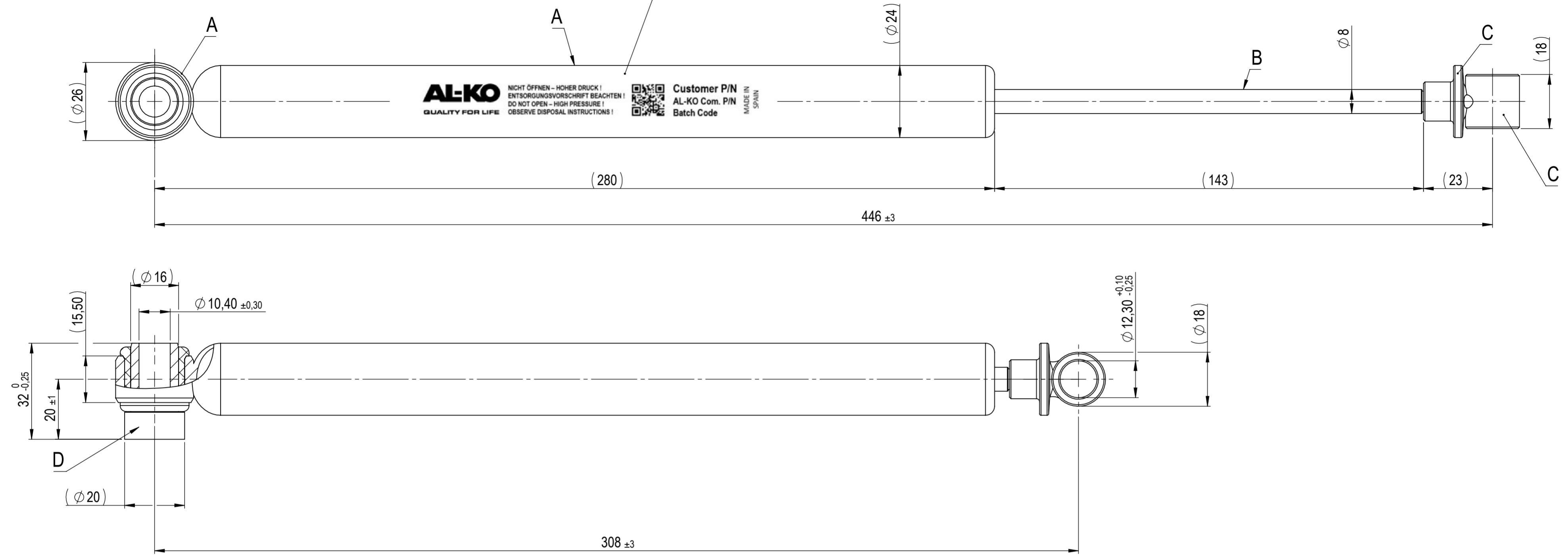

General Information	
• Customer:	AL-KO
Supply conditions:	
• Supply length:	extended
• Delivery unpreserved	
• Mounting parts:	free of paint
Permitted working / assembly conditions:	
• Permitted working temperature:	-30°C ...+85°C
Design Specifications:	
• Rebound stop	Not to be used as stroke limitation
• Endurance and functional test acc. to Standard:	WN 9.830.14
• Static load resistance:	N/A
• Marking acc. to AL-KO Standard:	20060701
• Marking acc. to drawing:	0128 (QR optional)
Protection against Corrosion	
• Finish A: Painted acc. to AL-KO Standard:	20110704 / f
• Finish B: Oxinitrided, alternatively chromium-plated acc. to AL-KO Standard:	20200406 / 4 (Oxinitrided) 20201105 / 5.3 (Chromium-plated)
• Finish C: Fe//Zn8//C (Free Cr+6)	EN ISO 2081
• Finish D: Fe//Zn12//A (Free Cr+6)	EN ISO 2081
Visual aspects:	
• Outer tube, painted	RAL 9011, black
Recycling:	
• According to AL-KO Standard:	WN 70001

AL-KO
 ALOIS KOBER GmbH
 Ichenhauser Str. 14
 D-89359 Kötzing
Document checked and approved.
 p.p.
 (digital signature)

Velocity	[mm/s]	100
Extension	[N]	1505 ¹⁸⁰⁵ ₁₂₀₅
Compression	[N]	600 ⁷²⁰ ₄₈₀
Response Threshold Ka v = 10mm/s	[N]	310 ³⁷⁰ ₂₅₀
Gas Force (5mm from extended length)	[N]	From 80 to 180
Test Temperature	[°C]	20 ± 5

This print is loaned on a confidential basis subject to return upon demand by AL-KO and nothing hereon may be reproduced, used or disclosed in whole or in part without the prior written permission of AL-KO. - All machined inside corners 0,8 mm radius. - Break all sharp edges - Remove all burrs, fins, flash and projections - General Tolerances acc. to ISO 2768 - m Permissible deviations for basic size range from 0,5 to 6 ± 0,1 from 6 to 30 ± 0,2 from 30 to 120 ± 0,3 from 120 to 400 ± 0,5	Tolerancing ISO 8015	General Tolerances Metal acc. to ISO 2768 medium Rubber acc. to DIN 7715 M3 Plastic acc. to DIN 16901	Scale: 1:1 Weight [g]: 425.84 Finish:	Sheet format size: A2
	Date: 17/11/2020 Name: jon.lauzinka	Description: Amt. M (E08) 359987		Part No. _ Revision: 1291616_00
AL-KO Ctra. Durango-Elorrio, N°25 48220 Abadiano, Spain	Alternative Ref.: 359987	Supersedes Ref.: N/A	Page 1 of 1	